

# LITHIONICS BATTERY®

LITHIUM-ION IRON PHOSPHATE BATTERY SYSTEMS



MODEL NUMBER:  
GT51V300A-F37-DIN-MODULE

EXTERNAL BMS  
VERSION

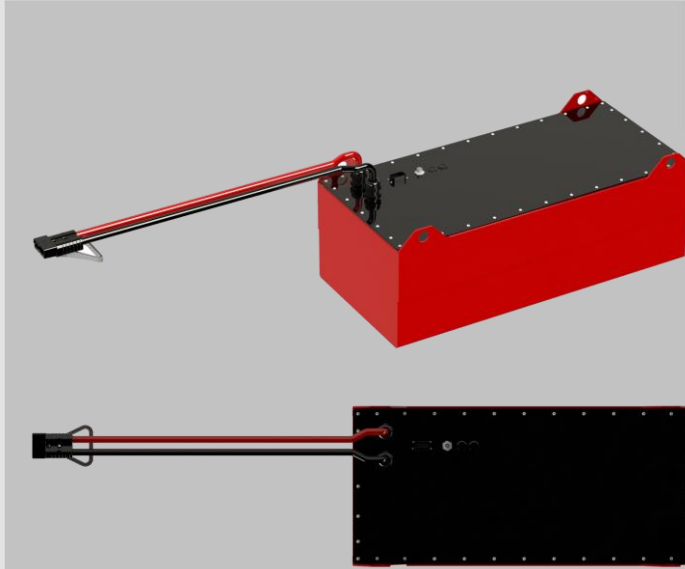

**EXTERNAL BMS REQUIRED**

BMS SOLD SEPARATELY. SEE BMS  
DATA SHEET PROVIDED BY LITHIONICS  
BATTERY®.

Item	Description	
Model	GT51V300A-F37-DIN-MODULE	
Nominal Voltage	56.8	
Nominal Capacity	300	
Nominal Watt Hours	17040	
Internal Resistance	<300 milliohms	
<b>Charge</b>		
Charging temperature range	32F/0C to 113F/45C	
Charge voltage	14.6	
Recommended float charge voltage(for standby use)	13.4	
Recommended charge current*	300	
Allowed max charge current*	400	
<b>Discharge</b>		
Discharging temperature range	-4F/-20C to 131F/55C	
Operating Voltage Range	11.6 to 13.4	
Recommended discharge current*	300	
Max discharge current*	400	
Pulse discharge current	3000	
Discharge cut-off voltage	NeverDie® Power Reserve @ 12.00 Low-Voltage Cut-Off @11.60	
<b>Mechanical</b>		
Dimensions	Length 37.4"	
	Width 17.4"	
	Height 14.0"	
Weight	Approx. 295lbs (134kg)	
<b>Storage</b>		
Storage Temperature & Humidity Range	< 1 Month	-4~95°F (-20~35°C), 45~75%RH
	< 3 Months	14~86°F (-10~30°C), 45~75%RH
	Recommended storage	59~95°F (15~35°C), 45%RH~75%RH
Long Term Storage	If the battery needs to be stored for > 3 months the voltage should be 13.2V (50%SOC), and stored at the recommended storage specifications shown above. Additionally, the battery needs at least one charge & discharge cycle every six months.	
Self-discharge rate	Residual capacity	≤3% per month; ≤15% per year
	Reversible capacity	≤1.5%per month; ≤8% per year

\* Maximum charging and discharging rates apply depending upon the ambient temperature and duty cycle of the system. ULI973 tests of maximum charge and discharge current were performed at 25°C/77°F



**NEVERDIE®**

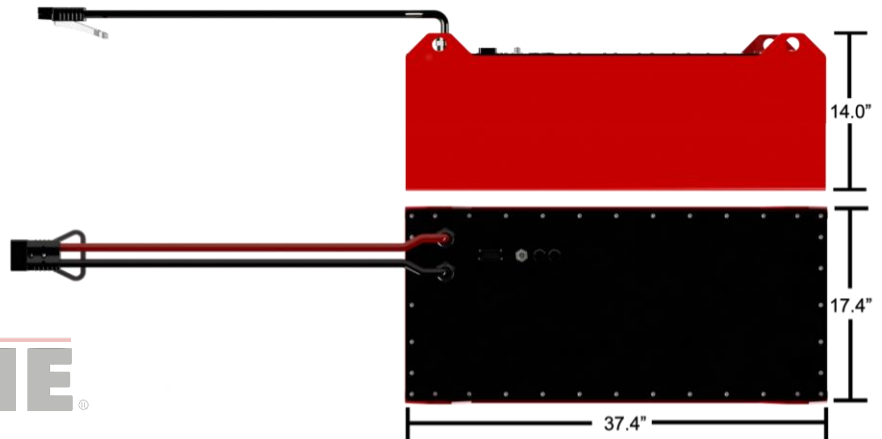

ENERGY

300 AMP HOURS

PULSE AMPS: 3000 (1SEC)

15380 WATT-HOURS

**WARNING**

- LITHIUM BATTERIES ARE NOT DESIGNED FOR CHARGING IN SUB-FREEZING TEMPERATURES. CONTACT LITHIONICS BATTERY® FOR DETAILS ON OUR COLD WEATHER PACKAGE.
- INSTALLATION: IT IS RECOMMENDED THAT BATTERIES BE INSTALLED CABLE OR TERMINAL SIDE UP.

NOTE: CONTACT LITHIONICS BATTERY® FOR A USER INSTALLATION GUIDE & STORAGE PROCEDURES. FOLLOW THE GUIDE TO ENSURE FITNESS OF USE & WARRANTY.

**51V**  
GT  
SERIES